

Color Management within a Spectral Image Visualization Tool

Mitchell R. Rosen, Mark D. Fairchild, Garrett M. Johnson, and David R. Wyble
Munsell Color Science Laboratory, Rochester Institute of Technology
Rochester, New York

Abstract

Recent developments in spectral imaging are pointing toward a future where the demands on color management will require a richer infrastructure than that which is currently offered. ICC color management includes a stage where all colors are transformed to and from XYZ-based colorspaces. This colorimetric bottleneck is acceptable within a metamerism or Maxwellian approach to color reproduction, but severely undermines the advantages of spectral imaging. Spectralizer, a spectral image visualization tool, has been implemented to provide a platform where spectral images may be easily displayed, manipulated, analyzed and processed. It has proven to be useful in investigating algorithms and prototype data-structures for performing the management of color within a spectral imaging environment.

Spectral Profiling of an Imaging Device

Source Devices

The spectral parameters to image capture are reasonably few. Figure 1 shows a simple schematic. A light source, or a number of light sources, radiate light illuminating objects or filtered through transparent or translucent objects. Some amount of the reflected or transmitted light travels through the optical system of an imaging device. As the radiation is followed, it encounters further filtration and then the detector itself. Light sources can be described by spectral power distributions, objects by spectral reflectance or transmittance properties, optical components and filters are associated with spectral transmittances and detectors have spectral sensitivities. If all of these properties are known and if other types of indirect illumination can be calculated from the scene then it is possible to create a model that reports the imaging system output given a particular input scene.

As in all profiling tasks, the inverse of the imaging model is of interest. If one were interested in determining object spectral reflectance given a particular digital output, such models have been reported.¹⁻⁵ However, without strict control over illumination, it may be impossible to create an inverse model that delivers reflectance for a given system response. When control over scene illumination cannot be guaranteed, an inverse model that reports scene radiance for a given digital output is feasible. Accuracy expectations

for either model will depend on the character of system channels and the level of *a priori* knowledge of scene object characteristics. For scanning devices, full knowledge of scene illumination is not an unreasonable demand and thus a spectral profile for such a device could indicate reflectance for given digital output. However, for a camera likely to be used in arbitrary environments, profiling the relationship between system digital count and estimated scene radiance is the appropriate strategy.

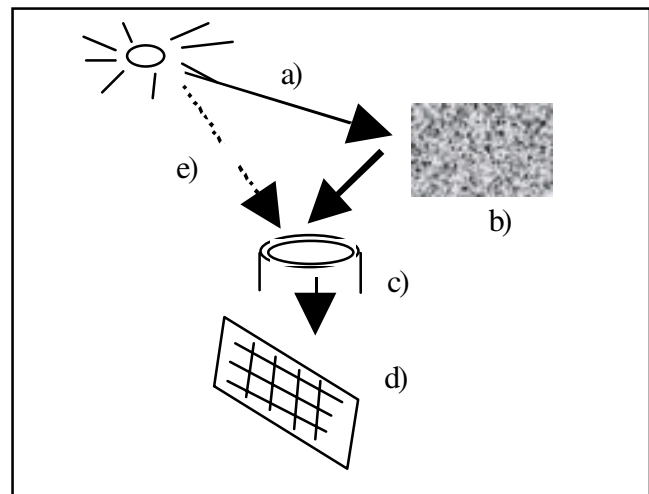

Figure 1: Spectral parameters to image capture: a) spectral power distribution of source, b) spectral reflectance (or transmittance) of object, c) spectral transmittance of optical and filter system, d) spectral sensitivity of detector, and, e) scene flare and specular highlights.

Destination Devices

Devices for image output can be broken into two broad categories: self-luminous devices such as monitors and reflective or transmissive devices such as ink-jet printers. Figure 2 illustrates a simplified outline of the spectral parameters for self-luminous output and Figure 3 shows a similar outline for reflective hardcopy. For the self-luminous example it is relatively straightforward to determine system radiance characteristics. It is clear that a spectral profiling approach for this type of device would be to characterize the relationship between spectral radiance and input digit. For a hardcopy device, output is either

reflective or transmissive. Light encounters the printed medium, interacts and then continues to the observer. Although the problem is far from trivial, the physics of hardcopy spectral reflectance has shown itself to be tractable.⁶ To profile a hardcopy device one must, thus, develop or obtain a digit to reflectance model for the printer/medium combination of interest and then invert it. Lookup table based approaches have been successfully used to store such inverted spectral models.^{1,7}

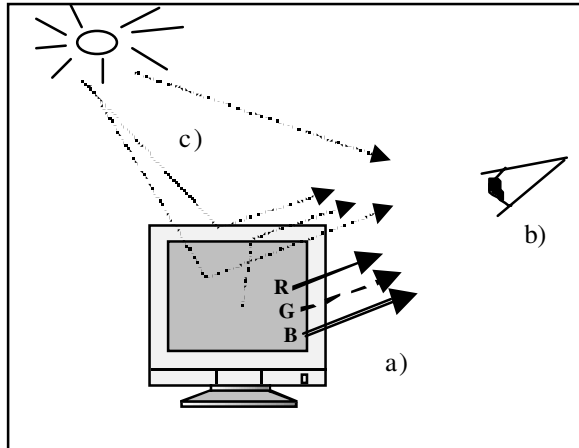

Figure 2: Spectral parameters to image display on a self-luminous device: a) individual channel spectral power distributions, b) spectral transmittance of eye optical system and spectral sensitivities of cones, and, c) flair from other sources as well as from the device itself.

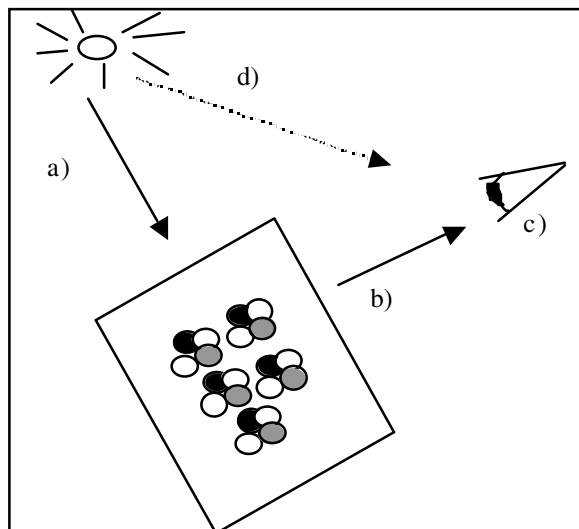

Figure 3: Spectral parameters to hardcopy presentation: a) spectral power distribution of source, b) spectral reflectance (or transmittance) of hardcopy, c) spectral transmittance of eye optical system and spectral sensitivities of cones, and, d) environmental flair and specular highlights.

Spectral Profiling Examples

A brief outline of justification for pairing most appropriate spectral profiling data transformations with specific device categories has been presented above. Table I summarizes the conclusions. For image capture devices where illumination is under strict control, in particular scanners, a digit to reflectance model is suggested. Other input devices such as digital cameras, should be characterized by a digit to radiance model. Monitors, as well, should be characterized with respect to radiance. Hardcopy output devices should have a reflectance to digit relationship encapsulated in their profiles. Output devices are sometimes treated as source devices. This is common for monitors; printers are treated this way primarily in proofing situations. Profiles for output devices should, thus, include models in both directions.

Table I. Data transforms for spectral profiles

Image Source/ Destination	Primary Data Transform	Secondary Data Transform
Scanner	digit to reflectance	-
Camera	digit to radiance	digit to reflectance*
Monitor	radiance to digit	digit to radiance
Printer	reflectance to digit	digit to reflectance

*For illuminant controlled studio capture

The goal described here is to store within a profile the relationship between digital count and scene radiance or the relationship between digital count and scene reflectance, depending on the device, as shown in Table I. It might be tempting to dismiss this goal as relevant only to futuristic multi-channel input devices and hi-fi multi-colorant output devices. In anticipation of these objections, below is introduced a series of thought experiments. The first two are highly contrived but in total the series provides insight into how a spectral color management approach differs from an ICC implementation even in workflows that at least partially relate to typical systems of today. The first thought experiment places a standard trichromatic camera at the front end; the second involves a typical CMYK printer at the back end; and, the third shows the use of a typical RGB scanner as input and a CMYK printer as output. Interest in spectral profiling should be motivated by showing that even within today's imaging paradigm of three channels in, four channels out, there is advantage to a spectral approach.

Before introducing the thought experiments, it is useful to outline the ICC approach to color management, shown in Figure 4. In the source-destination ICC model, a pair of profiled devices are interfaced through CMM image processing. The transformation applied by the CMM is a manipulation of the source image based on separate characterizations of the source and destination devices. These characterizations are delivered to the CMM within, respectively, a source and a destination profile. The effectiveness of the CMM transformation, and by extension the entire color management regime, is limited by the relevance of the data contained within the profiles. In an

ICC workflow, profile data relate device digits to colorimetry. It follows that the image processing actions of the CMM can be logically broken into two steps. The first step is one where the source profile is used to make the CMM cognizant of the relationship between source digits and colorimetry. In the second step through reference to the destination profile, the CMM anticipates the colorimetric properties of the destination device and chooses appropriate digits so that when rendered on the destination device the colorimetry that produced the source digits is preserved.

The ICC workflow described here is completely metameric. Whenever two non-identical spectra are confused by an input device, the CMM will always assume that the two colors map to the same colorimetric values. Unless the colors are also metameric to a human, this is an invalid assumption. Conversely, whenever two non-identical spectra are not confused by an input device, but they are by the standard observer, the CMM will in error treat the two as having distinct colorimetry.

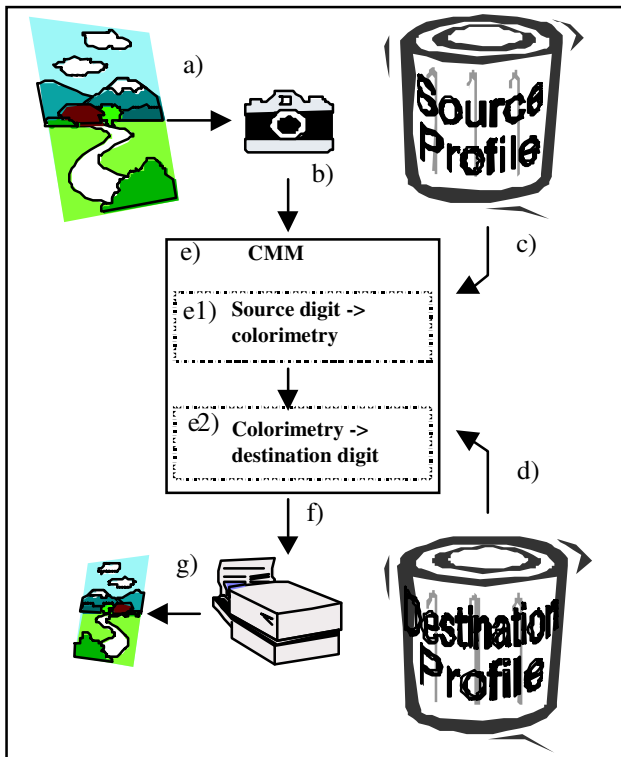

Figure 4: ICC source-destination model: a) scene irradiates camera, b) camera response fed to CMM, c) source profile informs CMM of digit to colorimetry relationship for source images d) destination profile informs CMM of colorimetry to digit relationship for destination device, e) CMM processes source image based on source and destination profiles, in logical steps, image is first e1) transformed to colorimetry, and second e2) transformed to destination digits, f) processed image fed to output device, and, g) rendered image produced.

An even more serious indictment of the ICC color management approach as it is outlined in Figure 4 is the fact that on the output side printers with more than three inks tend to have a tremendous amount of colorimetric redundancy. In other words, for many $L^*a^*b^*$ requests, there are a multitude of potential CMYK combinations that can fulfill the request. As any press craftsman will happily attest to, it takes careful consideration of the source image to choose how to create the black record for any particular situation. Once the black record is set, then the colorimetric redundancy problem is eliminated. The colorimetric bottleneck found in Figure 4 between steps e1 and e2 minimizes the chances for choosing the same CMYK that the craftsman would consider correct. In fact, the ICC approach is deterministic. For a particular source/destination profile combination all colors mapped by the source profile to the same colorimetry will always receive the same CMYK output.

Thought Experiment 1 - RGB Input

In the current ICC color management approach to an RGB camera, a source profile will typically relate camera digits to XYZ. Such a profile would be built by evaluating the response of the camera to a particular set of colored patches. In the ideal case, when a picture was taken of one of the same patches after building the ICC profile the CMM would transform the patch digits to the same XYZ value as that which was reported by a colorimeter directly measuring the physical patch. If a perfect colorimetric printer were available, the CMM would choose digits that when printed on this perfect printer would measure as the colorimeter reported XYZ. If some other scene were imaged by the camera and the same source profile used, due to differences between instrumental and human metamerism, it would be possible that a colorimeter in the scene would report a different XYZ than the XYZ derived through use of the ICC profile. Since the source profile leads the CMM to derive the wrong XYZ for a color, the color rendered on the perfect colorimetric printer would have a guaranteed visual mismatch with the original.

In the spectral profiling approach, a profile now relates camera digits to spectral radiance estimates. Such a profile would be, as in the ICC case, built by evaluating the response of the camera to a chosen set of colored patches. In the ideal case, a patch from the training set would be transformed by the spectral profile to the same spectral radiance as that reported by a radiometer directly measuring the physical patch. If the perfect spectral printer were used, printed patches would, under anticipated illumination, measure the same radiance as the original. When some other scene was imaged by the camera and the same spectral profile used, instrumental metamerism would make it possible that a radiometer in the scene would report a different radiance than one derived through use of the spectral profile. While the rendered color on the perfect spectral printer would have a spectral mismatch with the scene, human metamerism could still yield a visual match. Note, also, in this case, if the camera were to take a picture

of the rendered CMYK, it would not report a mismatch with the scene. The scene color and the printed color would be metameric to the camera!

Table II summarizes the differences shown above between the ways in which instrumental metamerism propagates errors under ICC and a spectral profiling approach.

Table II. ICC vs. Spectral Profiling: Error Propagation for an RGB Camera

	ICC	Spectral
error	color rendered as wrong XYZ	color rendered as wrong spectrum
looks to human	wrong color	maybe right, maybe wrong
looks to camera	wrong color	right color

Thought Experiment 2 - CMYK Output

In the ICC model, illustrated in Figure 4, there is no mechanism for source colors to be used in guiding the CMM among the redundancy found between colorimetry and CMYK output. Those tradeoffs are made at the profile making stage. This is a built-in deficit of the ICC approach. The most straightforward evidence for how this limitation hurts users is found when one examines an ICC proofing workflow where one CMYK printer is to emulate another. The ICC source-destination model offers no opportunity for the destination printer to be coerced into practicing GCR similar to the source printer.⁸ Beyond proofing, another obvious problem associated with making L*a*b* to CMYK decisions at profiling time is that matches are only guaranteed under a single illuminant, for ICC that being D50.

A spectral approach to CMYK profiling is a vast improvement over the ICC method. There is no redundancy problem when matching spectra. There is a single best choice to be made. In proofing situations where inks and printer physics are sufficiently similar, a spectral approach easily preserves GCR to within small deviations necessary for maintaining spectral integrity. Also, spectral matches are illuminant insensitive.

Table III summarizes these findings.

Table III. ICC vs. spectral profiling: CMYK generation.

	ICC	Spectral
GCR decisions	made at profiling time	made with respect to source spectra
proofing	arbitrary GCR	preserves GCR
sensitivity to illuminant	high	reduced

Thought Experiment 3 - RGB Scanner to CMYK Output

When considering a complete system consisting of typical imaging components of today, such as an RGB

scanner to a CMYK printer, all of the limitations associated with ICC color management found in Tables II and III are present. On the source end, instrumental and human metameric disagreements necessarily produce the wrong colorimetry. On the destination side, GCR is a predetermined aspect of the destination profile. This hurts proofing applications, or in this case applications where a printed page is scanned, and produces images where matches are not expected to hold beyond D50 illumination.

A spectral approach will, on the source end, absorb many spectral estimation errors because they will result in visual matches. On the output side, compared to the ICC approach, GCR matching will be under superior control when four-color input is scanned. High quality three channel scanners can often be profiled to produce highly accurate spectral estimates for well modeled three-colorant media. A spectrally profiled CMYK printer can take advantage of these estimates to produce matches that have low sensitivity to illuminant changes. .

A Spectral Image Profile

A prototype spectral profile is a three part data structure. For N channel images that relate to M spectral bands, the data structure consists of N 1-D LUTs, an MxN matrix, and M 1-D LUTs. An example for a profiled 6 channel device is shown in Figure 5. This structure is particularly useful for image input systems that are based on the capture of multiple wide band channels. The structure is not necessary for images that already contain narrow band spectral data.

The transformation from digital count to spectra is often determined through eigen vector analysis. A matrix applied to digital counts is used to determine weights for each eigen vector. The weighted eigen vectors are summed, resulting in the spectral estimation. It is a straightforward process to calculate coefficients for the spectral profile structure from the matrix and the eigen vectors. The structure is general enough that many alternative mappings can be encapsulated as well.

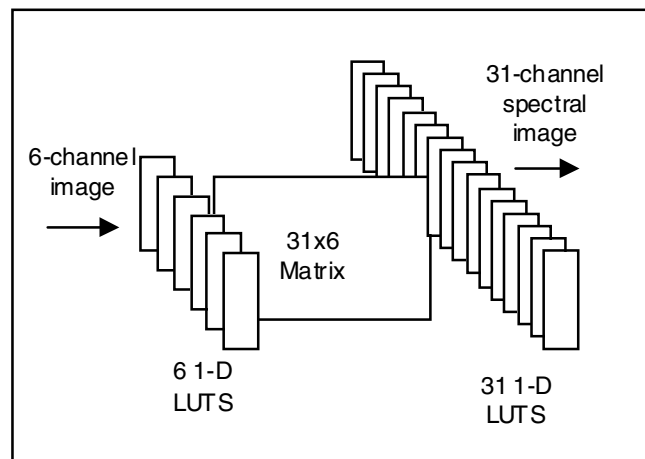

Figure 5: Example prototype spectral profile for converting a 6-channel image into 31 spectral bands.

Spectralizer: Spectral Image Visualization Tool

The motivation for building Spectralizer, a spectral image visualization tool, comes from the fact that although a growing database of spectral images has become available,^{1,2,5,9} there are few methods available to conveniently explore the full dimensionality of data represented by such images. In order to display spectral images, they are often reduced to three-channel RGB images. This preserves the two spatial dimensions but destroys all but some appearance attributes of the third, color dimension. Thus, an approach that displays spectral images and retains accessibility to their spectral underpinning is needed. Just as programs such as Photoshop are the basic tools of research within the 8-bit, three-band color imaging arena, spectral imaging research requires a visualization tool with sophisticated capabilities for multiple bands of 16-bit or floating-point data.

There is no standard method for storing multichannels of a spectral image at this time. Two common methods are supported by Spectralizer. These are multiple TIFF files and/or fields within the NCSA HDF10 file format. Three approaches to interpreting the color basis of the channels are offered. First, channels may be associated with narrow bands centered at specified wavelengths. Second, simple matrix-based transforms are accepted for relating the channels to narrow band estimates. A third type of image is described by a prototype spectral profile. Images may be specified as describing spectral reflectance or spectral radiance.

Figure 7 describes the logic flow of Spectralizer color management. The OPEN SPECTRAL IMAGE dialog box is illustrated in the upper right of Figure 7. Since the many channels of a single spectral image can be stored within multiple TIFF or HDF files, or can be stored as multiple fields within a single HDF file, the interface needs to be general enough to allow a user to associate files and fields with proper channel designations.

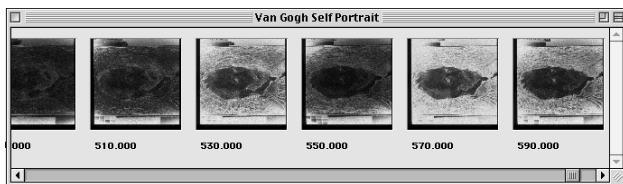

Figure 6: Opened spectral image prior to choosing a rendering method, treated as a collection of spectral channels.

When all the channels are assigned, Spectralizer opens the files and displays a *postage stamp strip* of the spectral channels, shown in Figure 6 and the second box of Figure 7. At this point the user may choose to analyze the image or she may choose to continue down the color rendering flow described in Figure 7. If she chooses to analyze the image, double clicking on any channel brings up a high

resolution view of that band or three channels can be chosen to be displayed as an RGB high resolution representative display of the image. Analysis tools currently include capability to query individual pixels for the original spectral description of that pixel or groups of pixels can be queried for average spectra. Image masks may be derived from matching pixel spectral characteristics and identification of pixels that become metameric pairs through a given imaging system model can be performed.

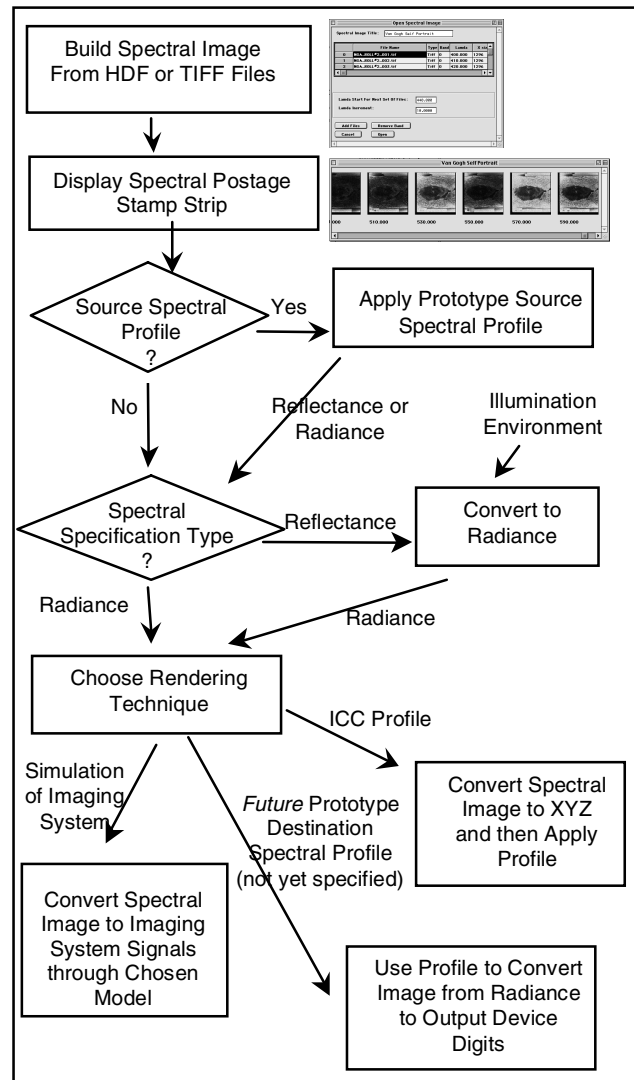

Figure 7: Spectralizer color management flow for rendering a spectral image.

For color rendering applications, after postage strip display, the system needs to be shown how to interpret the channels. As seen in Figure 7, if a source spectral profile is associated with the image, then this will be applied to the channels. Otherwise, the channels must be directly interpretable as narrow spectral bands. Reflectance images are transformed to radiance through the specification of an

illumination environment. Finally, the user chooses a rendering technique. Supported rendering methods include applying an image capture system model or transformation to XYZ followed by application of an ICC destination profile. For monitor display, this route is used. A future method will include applying a destination spectral profile for rendering on a hardcopy or display device. Rendered images may again be treated as a collection of bands, may be saved to file or they may be analyzed, as described above.

Upon completion of testing, the Spectralizer software code will be made freely available on the world wide web. Since the program is written in the IDL programming language, it is platform independent with support for Windows, Macintosh and Unix.

Conclusions

Spectral color management represents a new frontier to the color imaging community. Retrofitting the existing structure must be done carefully in order to preserve important aspects of a spectral image. A new prototype spectral profile has been presented with its use demonstrated in a spectral imaging environment. It has been shown that there can be advantage for spectral profiling of today's typical imaging devices. A research platform for spectral image visualization, Spectralizer, has been introduced. The software code will be made available to the imaging community following successful testing. It has become a useful platform for experimenting with spectral imaging "what if" scenarios. Through its color rendering interface the prototype spectral profile is being assessed.

References

- 1 M. Rosen, Lippmann2000: A spectral image database under construction, *International Symposium on Multispectral Imaging and Color Reproduction for Digital Archives*, Chiba, Japan, 1999, pp. 117-122.
- 2 F. Imai, M. Rosen and R. Berns, Comparison of spectrally narrow-band capture versus wide-band with *a priori* sample analysis for spectral reflectance estimation, submitted to CIC 2000.
- 3 B. Hill, Color capture, color management and the problem of metamerism: does multispectral imaging offer the

solution?, *Color Imaging: Device-Independent Color, Color Hardcopy, and Graphic Arts V*, R. Eschbach, G. G. Marcu, Editors, Proc. of SPIE **3963** Bellingham, WA, 2000, pp.2-14.

- 4 F. Imai and R. Berns, Spectral Estimation Using Trichromatic Digital Cameras, *International Symposium on Multispectral Imaging and Color Reproduction for Digital Archives*, Chiba, Japan, 1999, pp. 42-49.
- 5 Y. Miyake, Y. Yokoyama, N. Tsumura, H. Haneishi, K. Miyata and J. Hayashi, Development of multiband color imaging systems for recording of art paintings, *IS&T/SPIE Conference on Color Imaging: Device-Independent Color, Color Hardcopy, and Graphic Arts IV*, G. B. Beretta, and R. Eschbach, Editors, Proc. of SPIE **3648**, Bellingham, WA, 1999, pp. 218-225.
- 6 K Iino and R. Berns, "Building Color Management Modules Using Linear Optimization II. Prepress System for Offset Printing", *Journal of Imaging Science and Technology*, **42**, 2 (1998).
- 7 M. Rosen, F. Imai X. Jiang and N. Ohta, Spectral Reproduction from scene to Hardcopy II: Image Processing, submitted to Electronic Imaging, 2001.
- 8 M. Balonon-Rosen, J. Thornton, System and method for deriving an invertible relationship between color spaces where the intrinsic mapping is one-to-many for use in a color profile production system, U. S. Patent 6 072 901, 2000.
- 9 G. Johnson and M. Fairchild, Full-Spectral Color Calculations in Realistic Image Synthesis, *IEEE Computer Graphics and Applications*, **19**, 4 (1999).
- 10 NCSA, *The NCSA HDF Home Page*, hdf.ncsa.uiuc.edu

Biography

Mitchell Rosen is a senior color scientist with the Munsell Color Science Laboratory of R.I.T.'s Center for Imaging Science. Before joining R.I.T., he spent ten years in imaging research and development as a member of Polaroid's Image Science Laboratory. His research in the Munsell Lab grows out of recognition that widespread efforts to capture spectral images have introduced new challenges for image processing and new opportunities for improved quality in color reproduction. He is also a candidate in R.I.T.'s Imaging Science doctorate program. He is a member of IS&T.